

# True On-line Double Conversion High Performance High Density, High Efficiency Uninterruptible Power Supply

**M9950 Series**  
100kVA~600kVA



## True On-line Double Conversion High Performance UPS

- ◆ Power rating from 100kVA to 600kVA
- ◆ All-IGBT 3 level innovative circuit concept
- ◆ High power quality at high efficiency up to 96%
- ◆ Compact design, Small footprint / lightweight
- ◆ High Performance
  - Full digital control, instantaneous waveform control,
  - fast-response current control
- ◆ Configurable for Higher Reliability
  - Intelligent Flexible MMS Capability (Up to 8 units)
- ◆ Front access, Multiple cable entry points
  - More versatility (Top/Bottom)

## UPS System Configuration

### ■ Single Module System UPS

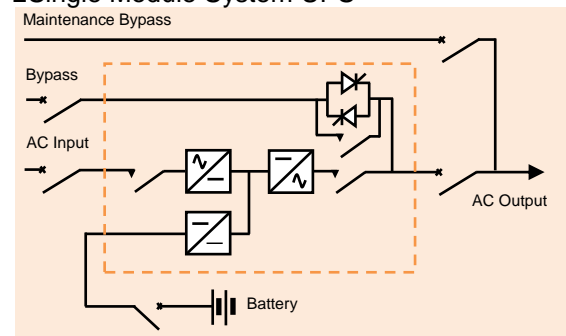

### ■ Multi Module System UPS

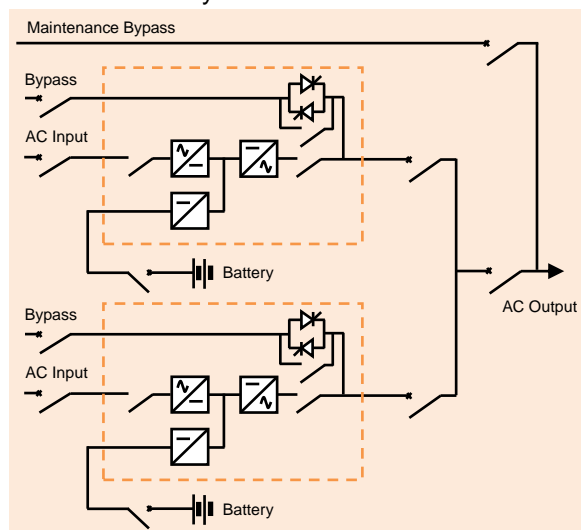

# 【SPECIFICATION】

DESCRIPTION	M9950 Series							
Rating (kVA)	100	120	160	200	300	400	500	600
Design Topology	Online double conversion (VFI-SS-III), Transformerless design							
Regulatory	Safety : IEC 62040 -1, EMC : IEC 62040 -2, Performance : IEC 62040 -3							
Power Expansion	Upto 8 units with advanced current mirror loop control for reliable parallel operation							
Surge Protection	Built-in modular type II surge protection							
Emergency Power off (EPO)	Available in front panel							
Cable Entry <sup>1</sup>	Bottom							
Protection Class	IEC-IP-20							
Colour	Grey RAL 7032							
<b>Input Characteristics</b>								
Converter Technology	Robust CSTBT based multi-level Technology, High Efficiency & Long life							
Nominal Voltage	3Phase 380/400/415 V + PE							
Voltage Tolerance	+15%, -20%							
Frequency	50 Hz $\pm$ 10%							
Power Factor	0.99							
Current Distortion (THDi) @ Rated Load <sup>2</sup>	3%							
System Power Walk in	30 secs programmable and up to 3600 secs programmable converter start delay							
<b>Output Characteristics</b>								
Inverter Technology	Robust CSTBT based multi-level Technology, High Efficiency & Long Life							
Nominal Voltage	3Phase-4 Wire 400/415 V (selectable)							
Frequency	50 Hz							
Frequency Sync Range	$\pm$ 1% to $\pm$ 5% (Selectable in 1% increment)							
Frequency Slew Rate	1 Hz/sec to 5 Hz/sec (Selectable in 1 Hz/sec increment)							
Phase Displacement	$\pm$ 1 Deg @ 100% balanced load, $\pm$ 3 Deg @ 100% unbalanced load							
Power Factor	Unity							
Voltage Regulation Static Load	< 1%							
Dynamic Response (100% Step Load)	< 2%, recovery within 20ms							
Voltage Distortion (THDv) @ Rated Load	< 2% Linear load, < 3% Non-linear load							
Over Load	110% for 60 Minutes, 125% for 10 Minutes, 150% for 1 Minute							
<b>Bypass Characteristics</b>								
Nominal Voltage	3 Phase - 4wire 400/415V +/-10%							
Nominal Frequency	50Hz							
Short Circuit withstand Capacity	500% for 20ms							
Ecomode with PF & Harmonics Correction	Available as a value-added optional feature (Smart Drive)							
<b>Battery</b>								
Nominal Voltage	480 VDC (Flexible)							
Max DC Voltage Protection	Upto 700 VDC							
Battery Type	VRLA, Flooded, Ni-Cd, LIB							
<b>Efficiency</b>								
Double Conversion Mode	Upto 96.5%							
Smart Drive Mode (Optional Feature)	Upto 98.5%, Upto 99% Eco mode							
<b>Communication</b>								
Intelligent Monitoring (Option)	Modbus/TCP, Modbus/RS485, RS 232, SNMP							
UPS Display	Graphical Touchscreen with LCD Display							
Alarm and Status Information	Through LCD Display, user programmable input and output dry contacts							
<b>Environmental Conditions</b>								
Operating Temperature <sup>4</sup>	0 to 40° C							
Relative Humidity	5 to 95% non-condensing							
Operating Altitude	1000m above MSL without derating							
<b>Physical</b>								
Dimension (W x D x H) <sup>3</sup>	700 x 832 x 2080	700 x 832 x 2080	1400 x 832 x 2080	1600 x 832 x 2080				
Weight (kg)	550	550	610	610	990	1100	1590	1650

Specifications are subject to change without prior notice as part of continuous development.

1 - Top entry optional on request 2 - With source THDv < 1% 3 - Dimension tolerance  $\pm$ 10 mm 4 - As per maintenance guidelines detailed in user manual